

# TriTech

MADE IN THE U.S.A.

# T7

## 302-116REVC

PROFESSIONAL AIRLESS SPRAYER

MAXIMUM WORKING PRESSURE 3300PSI 227BAR 22.7 MPa

VOLTS	CYCLES	AMPS	PHASE
110V	50/60	13	SINGLE
220V	50/60	7	SINGLE

Patents pending

FOR THE APPLICATION OF ARCHITECTURAL PAINTS AND COATINGS

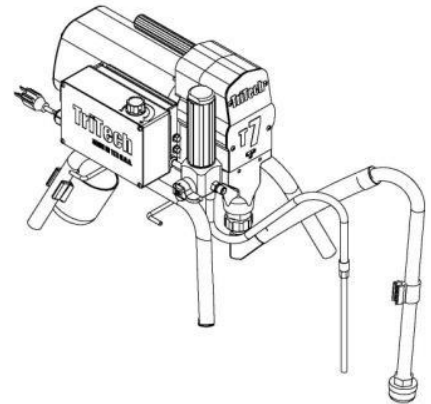
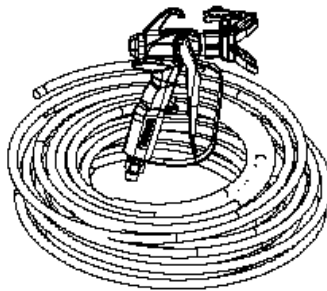
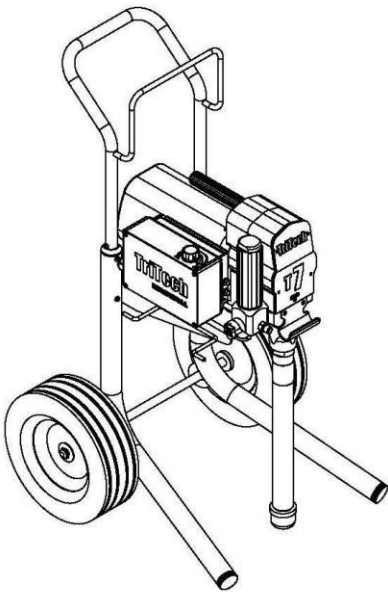

**!! SAFETY AND OPERATING INSTRUCTIONS INSIDE !! Read all warnings and safe operating information inside. SAVE THIS MANUAL FOR FUTURE REFERENCE**

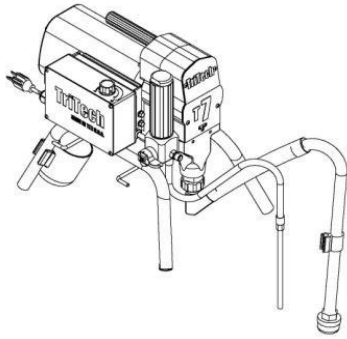

600-830	T7 STAND COMPLETE 120V
600-840	T7 STAND COMPLETE 220V
600-852	T7 UK STAND COMPLETE 120V

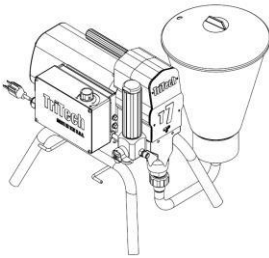

600-832	T7 HOPPER COMPLETE 120V
600-842	T7 HOPPER COMPLETE 220V

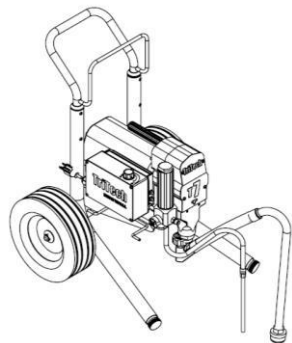

600-836	T7 LO CART COMPLETE 120V
600-846	T7 LO CART COMPLETE 220V

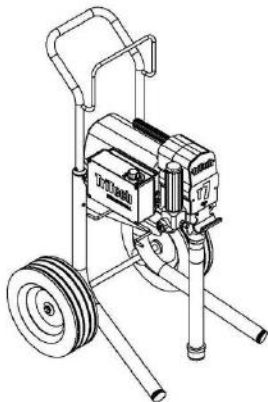

600-844	T7 HIGH CART COMPLETE 220V
600-834	T7 UK HIGH CART COMPLETE 120V
600-852	T7 UK HIGH CART COMPLETE 120V

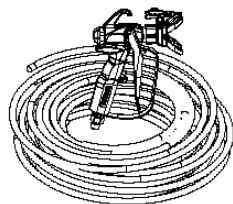

501-155	T360 AIRLESS SPRAY GUN
200-517	T93R AIRLESS TIP
200-999	T93R AIRLESS GUARD
400-114	50' ¼" AIRLESS HOSE

## WEEE Compliance



## Statement

The mark shown to the right is in compliance with the Waste Electrical and Electronic Equipment Directive 2002/96/EC (WEEE).

The mark indicates the requirement NOT to dispose of the equipment as unsorted municipal waste, but use the return and collection systems according to local law. Users should contact their supplier and check the terms and conditions of the purchase contract. When purchased directly from TriTech Industries, or a TriTech Industries Distributor you may contact technical support for disposal arrangements.

## RoHS Compliance Statement

TriTech Industries products are designed to meet Reduction of Hazardous Substance Directive 2011/65/EU 8June2011, the product manufactured by TriTech Industries do not contain materials that exceed thresholds for cadmium, mercury, hexavalent chromium, Polybrominated diphenyl ethers (PBDEs) or other regulated substances.

## Safety Compliance Statement

TriTech Industries product are certified meeting UL 1450 Issued: 2010/05/05 Ed: 4 Rev: 2013/11/01 Motor-Operated Air Compressors, Vacuum Pumps, & Painting Equipment and CSA C22.2#68 Issued: 2009/09/01 Ed: 7 Motor-Operated Appliances (Household and Commercial)-General Instruction No 1 : 2010/02/01 - General Instruction No. 2: 2010/09/28. TriTech Industries products are designed to conform to EN 55014-1 Issue:2006/12/01 *Electromagnetic compatibility Requirements for electric tools and similar apparatus*, EN 55014-2 Issued:2001/12/01 *EMC - Requirements for Electric Tools and Similar Apparatus*, and European Union Low Voltage Directive (LVD) 2006/95/EC

## WARNINGS AND START UP PROCEEDURE

### WARNINGS

Below are general warnings related to the use and maintenance, safe grounding and repair of the TriTech airless paint sprayers. Additional warnings are found throughout this manual where applicable. Symbols appearing in the manual refer to these warnings. Refer back to these pages for the symbol's description of the specific hazard.

### FIRE AND EXPLOSION HAZARD

Flammable fumes, such as solvent and paint fumes, in work area can ignite or explode. To help prevent fire and explosion:

- Use equipment only in well ventilated area.
- Eliminate all ignition sources; such as pilot lights, cigarettes, portable electric lamps, and plastic drop cloths which may present a potential static arc.
- Sprayer generates sparks. When flammable liquid is used in or near the sprayer or for flushing or cleaning, keep sprayer at least 20 feet (6 m) away from explosive vapors.
- Keep work area free of debris, including solvent, rags and gasoline.
- Do not plug or unplug power cords or turn lights on or off when flammable fumes are present.
- Ground equipment and conductive objects in work area. Refer to the Grounding instructions.
- If there is static sparking or you feel a shock, stop use immediately. Do not use equipment until you identify and correct the problem.
- Keep a fire extinguisher in the work area.

### ELECTRIC SHOCK HAZARD

Improper grounding, setup, or usage of the system can cause electric shock.

- Turn off unit and unplug power cord before servicing equipment.
  - Use only 3-wire extension cords and plug into only grounded electrical outlets.
  - Ensure ground prongs are intact on sprayer's power cord and extension cords.
- **CAUTION:** To reduce the risk of electrical shock, do not expose to rain. Store indoors.

## **SKIN INJECTION HAZARD**

High-pressure fluid from tip, gun, hose leaks, or ruptured components will pierce skin. This may look like just a cut, but it is a serious injury that can result in amputation. Get immediate surgical treatment.

- Do not point gun at anyone or at any part of the body.
- Do not put your hand over the spray tip. Use only spray tip specified by TriTech.
- Do not stop or deflect leaks with your hand or body, glove, or rag.
- Engage trigger lock when not spraying.
- Follow Pressure Relief Procedure in this manual, when you stop spraying and before cleaning, checking or servicing equipment.

## **EQUIPMENT MISUSE HAZARD**

### **IMPORTANT SAFETY INSTRUCTIONS**

Misuse can cause death or serious injury.

- Do not exceed the maximum working pressure or temperature rating of the lowest rated system component. Read Technical Data in all equipment manuals. Use only spray tip specified by TriTech.
- Use fluids and solvents that are compatible with equipment wetted parts. Read Technical Data in all equipment manuals. Read fluid and solvent manufacturer's warnings. For complete information about your material, request MSDS from your coatings supplier TriLube MSDS are supplied with this unit.
- Check equipment daily. Repair or replace worn or damaged parts immediately with genuine TriTech replacement parts only. Use only spray tip specified by TriTech.
- Do not alter or modify equipment.
- Use equipment only for its intended purpose. Call TriTech customer service or your TriTech distributor for information.
- Route hoses and cables away from traffic areas, sharp edges, moving parts, and hot surfaces. If the spray hose is required to be replaced, replace with identical hose supplied with the sprayer.
- Do not kink or over bend hoses. Do not use the hose as a strength member to pull or lift the equipment.
- Comply with all applicable safety regulations.
- Keep children and animals away from work area.

- Do not operate the unit when fatigued or under the influence of alcohol or drugs. Stay alert and watch what you are doing.
- Know how to stop the unit and bleed pressure quickly. Be familiar with controls.
- Do not overreach or stand on an unstable support. Keep effective footing and balance at all times.

## **A PRESSURIZED ALUMINUM PARTS HAZARD**

Do not use 1,1,1-trichloroethane, methylene chloride, other halogenated hydrocarbon solvents or fluids containing such solvents in pressurized aluminum equipment. Such use can cause serious chemical reaction and equipment rupture, and result in death, serious injury, and property damage.

## **TOXIC FLUID OR FUMES HAZARD**

Toxic fluids or fumes can cause serious injury or death if splashed in the eyes or on skin, inhaled, or swallowed.

- Read all MSDS's to know the specific hazards of the fluids you are using.
- Store hazardous fluid in approved containers, and dispose of it according to applicable guidelines.

## **PERSONAL PROTECTIVE EQUIPMENT**

You must wear appropriate protective equipment when operating, servicing, or when in the operating area of the equipment to help protect you from serious injury, including eye injury, inhalation of toxic fumes, burns, and hearing loss. This protective equipment includes but is not limited to;

- Protective eye wear
- Clothing and respirator as recommended by the fluid and solvent manufacturer
- Gloves
- Hearing protection

## **GROUNDING:**

The sprayer must be grounded. Grounding reduces the risk of static and electric shock by providing an escape wire for the electrical current due to static build up or in the event of a short circuit.

- The sprayer power cord includes a grounding wire with an appropriate grounding contact.
  - The plug must be plugged into an outlet that is properly installed and grounded in accordance with all local codes and ordinances.
  - Do not modify plug. If it will not fit in outlet have grounded outlet installed by a qualified electrician. Do not use an adapter.
- Use only the correct pressure rated airless hose with static ground to reduce the risk of static discharge or injection.

## **POWER REQUIREMENTS**

- 110V units required 100-120VAC 50/60Hz, 13A, 1 phase
- 220V units require 220-240 VAC, 50/60Hz, 7A, 1 phase

## **EXTENSION CORDS**

- Use an extension cord with ground contact only. Should an extension cord be necessary use a 3 wire, 12 AWG (2.5mm<sup>2</sup>) minimum. Do not exceed 300 ft 100 meters

## **PAILS**

- Solvent and oil based fluids: follow local code. Use only conductive metal pails, place on a grounded surface such as concrete.
- Do not place pail on a nonconductive surface such as paper or cardboard which interrupt grounding continuity.
- To maintain grounding continuity when flushing or relieving pressure: hold metal part of the spray gun with the airless tip removed firmly to side of the grounded metal pail. Then trigger gun.

## **START UP**

Throughout these instructions Model # T-5 and T-7 and the instructions for the T360 Airless spray gun are shown in all illustrations.

1. Connect TriTech airless hose to sprayer. Tighten securely.
2. Connect other end of the hose to gun.
3. Tighten securely.
4. Remove tip guard.
5. Check inlet strainer for clogs and debris.
6. Fill upper retainer with TriLube to prevent premature packing wear. Do this each time you spray.
7. Plug power supply cord into a properly grounded electrical outlet.
8. Turn pressure relief valve down.
9. Place siphon tube set in grounded metal container partially filled with flushing fluid. Use mineral spirits to flush storage oil.
  
10. Turn pressure control to lowest pressure. Turn pressure relief valve down.
11. Turn power ON.
12. Increase pressure to start motor and allow fluid to circulate through pressure relief tube for 15 seconds; then turn pressure down.
13. Turn pressure relief valve horizontal. Take spray gun trigger safety OFF.
14. Hold gun against grounded metal container. Trigger gun and increase fluid pressure to half way. Flush 1 minute. Inspect for leaks. If a leak occurs follow the pressure relief procedure then tighten fitting were leak occurred. Do not attempt to stop leaks with hand or rag! Repeat Start-up 1-5 again. If no leaks, proceed.
15. Place siphon tube in paint pail.
16. Trigger gun again into metal container until paint appears. Move gun to paint pail and trigger for 20 seconds. Set the safety to ON position. Assemble tip and guard. (See following section).

## **TIP AND GUARD ASSEMBLY**

1. Insert metal seal and "black bellow" seal assembly by placing seals on the end of T93R Contractor tip and insert through guard. Line up seals by turning tip.
2. Insert Tip
3. Screw assembly onto gun. Tighten.

## **SPRAYING**

1. Spray test pattern. Start with pressure turned to its lowest setting, then gradually increase pressure until you achieve a consistent spray pattern without heavy edges. Use smaller tip size if pressure adjustment cannot eliminate heavy edges.
  
2. Hold gun perpendicular 10-12 inches in of front surface. Spray back and forth overlapping by 20%. To prevent heavy spots, start moving the gun before pulling the trigger. When spraying, after releasing trigger continue to move gun.

#### CLEARING CLOGGED TIP

- a) Release trigger, put safety ON.
- b) Rotate T93R Tip.
- c) Take safety OFF
- d) Trigger gun to clear clog. Never point gun at your hand or in a rag!

#### RETRUN TO SPRAY

- a) Put Safety ON.
- b) Return Tip to spray position.
- c) Take safety OFF and continue spraying.

#### CLEAN UP

1. Turn power OFF and unplug sprayer.
2. Turn pressure to lowest setting. Trigger gun to relieve pressure.
3. Put pressure relief tube in pail. Turn pressure relief valve down.
4. Remove guard and T93R tip. Clean tip with soft bristle brush. **DO NOT STORE IN WATER.**
5. Remove siphon tube set from paint and place in flushing fluid. Use water for water base paint and mineral spirits for oil base paint.
6. Plug in sprayer. Turn power ON. Return Pressure relief valve to its horizontal position.
7. Hold gun against paint pail. Take trigger safety OFF. Trigger gun and increase pressure until flushing fluid appears.
8. Move gun to flushing pail, hold gun against pail. Trigger gun to thoroughly flush system. Release trigger and put trigger safety ON.
9. Turn pressure relief valve down and allow flushing fluid to circulate for 1 to 2 minutes to clean drain tube.
10. Raise siphon tube above flushing fluid and run sprayer for 15 to 30 seconds to drain fluid. Turn power off.
11. Close pressure relief valve. Trigger gun into flushing pail to purge fluid from hose.
12. Turn pressure relief valve down to insure there is no pressure in the unit. Then retrain pressure relief valve to its horizontal position. Do not store with pressure relief valve down.
13. Remove filter from gun and sprayer, if installed. Clean and inspect. Reinstall filters.
14. If flushing with water, flush again with mineral spirits or TriTech Pump Cleaner to leave a protective coating to prevent freezing or corrosion.
15. Unplug power cord from outlet and wipe sprayer, hose and gun with rag soaked in water or mineral spirits.



## Pressure Relief Procedure

The sprayer's pressure must be manually relieved to prevent sprayer from starting or spraying accidentally.

Fluid under high pressure can be injected through skin and cause serious injury. To reduce risk of injury from injection, splashing fluid, or moving parts,

Follow the **Pressure Relief Procedure** whenever you:

- are instructed to relieve pressure
- stop spraying
- check or service any system equipment
- install or clean spray tip

### PROCEDURE

1. Turn pressure control knob counterclockwise to stop.
2. Turn sprayer off.
3. Do not unplug power supply cord.
4. Hold metal part of gun firmly to grounded metal container. Trigger gun to relieve pressure.
5. Lock gun safety latch.
6. Open pressure relief valve. Leave pressure relief valve open until ready to spray again.

**NOTE:** Do not store unit for extended periods of time with the Pressure Relief Valve open. Store the unit in the spray position.

**NOTE:** If suspected that spray tip or hose is completely clogged, or that pressure has not been fully relieved after following steps above,

**SLOWLY** loosen tip guard or hose end coupling to relieve pressure gradually, and then loosen completely. Clear tip or hose obstruction.

### ELECTRICAL SHOCK WARNING

To reduce risk of serious injury, including electric shock, do not touch moving or electrical parts with fingers or tools while testing repair. Shut off and unplug sprayer when inspection is complete. Install all covers, guards, gaskets, screws and washers before operating sprayer.

PROBLEM	WHAT TO CHECK	REMEDY
Motor will not turn on.	<ol style="list-style-type: none"> <li>1. Unit not plugged in.</li> <li>2. Pressure set too low</li> <li>3. Circuit breaker open</li> </ol>	<ol style="list-style-type: none"> <li>1. Plug unit in.</li> <li>2. Increase pressure</li> <li>3. Check breaker and reset if needed.</li> </ol>
Unit will not prime	<ol style="list-style-type: none"> <li>1. Inlet tube is loose</li> <li>2. Inlet screen clogged</li> <li>3. Inlet ball stuck</li> <li>4. Outlet ball stuck</li> </ol>	<ol style="list-style-type: none"> <li>1. Check o-ring and tighten siphon hose</li> <li>2. Check inlet screen clean or replace</li> <li>3. Remove siphon hose assy and move inlet ball with pencil.</li> <li>4. Remove siphon hose and foot valve and use pencil to move outlet ball.</li> </ol>
Pump builds pressure but will not shut off	<ol style="list-style-type: none"> <li>1. Inlet ball or seat obstructed or chipped</li> <li>2. Outlet ball or seat obstructed or chipped</li> <li>3. Prime valve leaks.</li> </ol>	<ol style="list-style-type: none"> <li>1. Clean or replace if needed</li> <li>2. Clean or replace if needed</li> <li>3. Replace Prime Valve if coating leaks while under pressure.</li> </ol>
Paint leaking front wet cup	<ol style="list-style-type: none"> <li>1. Inspect upper packing.</li> </ol>	<ol style="list-style-type: none"> <li>1. Replace if needed</li> </ol>
Pump output is low	<ol style="list-style-type: none"> <li>1. Spray tip worn</li> <li>2. Lower or Upper ball worn</li> <li>3. Prime valve worn</li> </ol>	<ol style="list-style-type: none"> <li>1. Inspect tip by checking fan pattern width. If worn replace</li> <li>2. Inspect lower and upper ball for damage. Replace if damaged or worn.</li> <li>3. If prime valve leaks while spraying clean or replace.</li> </ol>
<p><b>NOTE:</b> Before performing any inspection or repair follow the pressure relief procedure. Never attempt to do any service or repair while the unit is plugged in or under pressure.</p>		



## EC- DECLARATION OF CONFORMITY

**Model** T4, T5, T7, T9, T11

**Part Number**

600-800, 600-801, 600-802, 600-803, 600-804, 600-805, 600-806, 600-807, 600-810  
600-811, 600-812, 600-813, 600-814, 600-815, 600-816, 600-817, 600-830, 600-831  
600-832, 600-833, 600-834, 600-835, 600-836, 600-837, 600-840, 600-841, 600-842  
600-843, 600-844, 600-845, 600-846, 600-847, 600-850, 600-851, 600-852, 600-853  
602-804, 602-806, 602-814, 602-816, 602-834, 600-836, 600-844, 600-846

**Complies with the EC Directives:** 2006/42/EC Machinery Directive

**Standards Used:** ISO 1200, ISO 3744

**Approved by:**

*Dan Hosley*

Dan Hosley

Vice President of Sales & Marketing

**Manufactured by:** January 14, 2014

TriTech Industries Inc.

610 Rahway Avenue

Union, NJ 07083 U.S.A.

302-119B



EXTENSION CORD VOLTAGE DROP				
120V	15 AMP	100'	200'	300'
14 AWG		110.6	101.2	91.8
12 AWG		114.1	108.1	102.2
10 AWG		116.3	112.5	108.8
LINE LOSS 1/4" HOSE STANDARD LATEX PAINT				
HORIZONTAL	AT PUMP		AT TIP	
50'	3300PSI	227 BAR	3150	217 BAR
100'	3300PSI	227 BAR	3100	213 BAR
150'	3300PSI	227 BAR	3050	210 BAR
200'	3300PSI	227 BAR	3000	207 BAR
250'	3300PSI	227 BAR	2950	203 BAR
300'	3300PSI	227 BAR	2900	199 BAR
VERTICLE				
50'	3200	220 BAR	3135	216 BAR
100'	3200	220 BAR	3070	211 BAR
150'	3200	220 BAR	3005	209 BAR
200'	3200	220 BAR	2940	202 BAR
250'	3200	220 BAR	2875	198 BAR
300'	3200	220 BAR	2810	193 BAR

### Pressure Relief Procedure

The sprayer's pressure must be manually relieved to prevent sprayer from starting or spraying accidentally.

Fluid under high pressure can be injected through skin and cause serious injury. To reduce risk of injury from injection, splashing fluid, or moving parts,

Follow the **Pressure Relief Procedure** whenever you:

- are instructed to relieve pressure
- stop spraying
- check or service any system equipment
- install or clean spray tip

Turn pressure control knob counterclockwise to stop.

2. Turn sprayer off.
3. Unplug power supply cord.
4. Hold metal part of gun firmly to grounded metal container. Trigger gun to relieve pressure.
5. Lock gun safety latch.
6. Open prime valve. Leave prime valve open until ready to spray again.

**NOTE:** Do not store unit for extended periods of time with the Pressure relief valve open. Store the unit in the spray position.

**NOTE:** If suspected that spray tip or hose is completely clogged, or that pressure has not been fully relieved after following steps above,

**SLOWLY** loosen tip guard or hose end coupling to relieve pressure gradually, and then loosen completely. Clear tip or hose obstruction.

**(A) FLUID MANIFOLD**

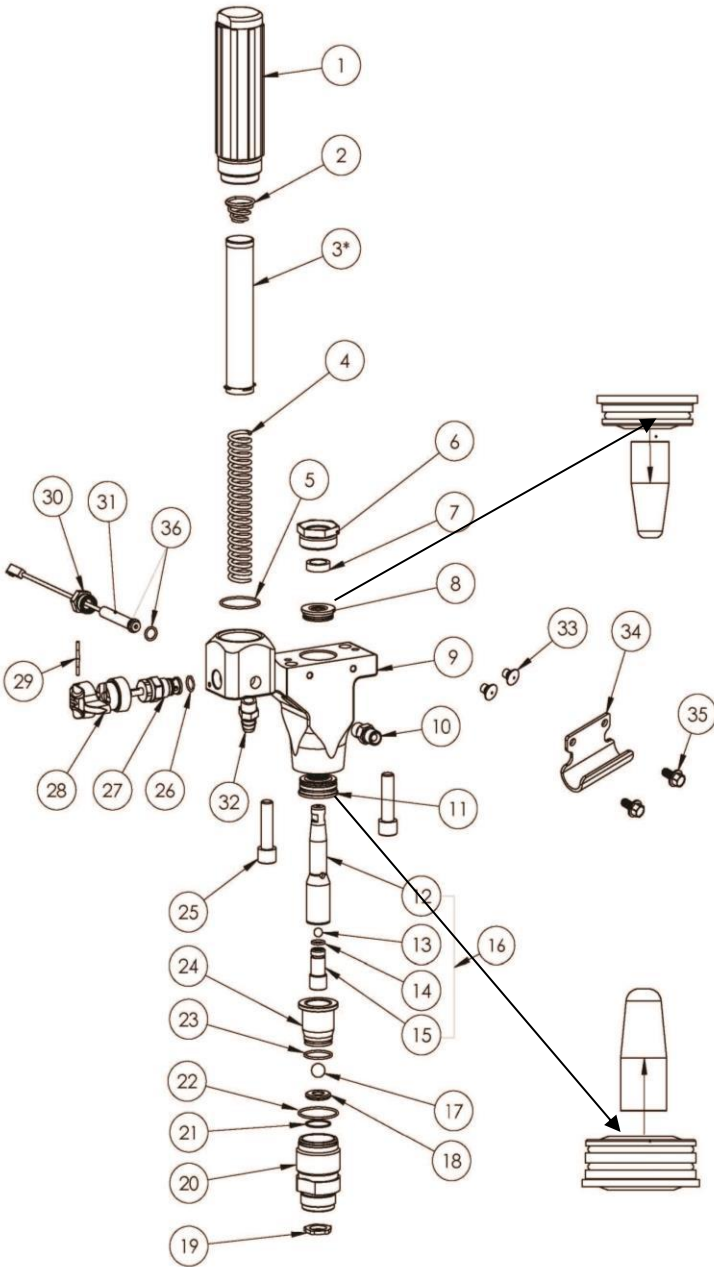

ITEM NO	PART NO.	DESCRIPTION	QTY
1	600-211	HOUSING, FILTER	1
2	600-255	SPRING, FILTER	1
3	600-141-05	FILTER, 50 MESH	1
4	600-240	CORE, SPRING	1
5	600-353	O-RING	1
6	600-033	RETAINER, UPPER	1
7	600-035	GUIDE, UPPER	1
8	600-017	PACKING, UPPER	1
9	600-0083-75	MANIFOLD, FLUID	1
10	120-001	FITTING, HOSE	1
11	600-024	PACKING, LOWER	1
12	600-099-75	ROD, PISTON	1
13	600-047	BALL, UPPER	1
14	101-001	O-RING	1
15	600-118-75	VALVE, PISTON (INCL.14)	1
16	600-090-75	ROD, PISTON COMPLETE (12-15)	1
17	600-022	BALL, INTAKE	1
18	600-021	SEAT, INTAKE VALVE	1
19	600-234	WASHER	1
20	600-251	HSG, INTAKE VALVE (INCL.19-22)	1
21	600-279	INTAKE VALVE	1
22	600-353	O-RING	1
23	600-367	O-RING	1
24	600-249	GUIDE, PISTON (INCL.23)	1
25	600-199	BOLT	2
26	600-166	O-RING	1
27	600-157	VALVE, PRESSURE RELIEF (INCL.26)	1
28	600-437	HANDLE & CAM (INCL.29)	1
29	600-214	PIN, PRESSURE RELIEF	1
30	600-030	HSG, TRANSDUCER	1
31	600-456	TRANSDUCER (INCL.30-31,36)	1
32	600-208	FITTING, HOSE, BARB MALE	1
33	600-242	PLUG, BRACKET MOUNT	2
34	600-320	HOOK, PAIL (HI CART ONLY)	1
35	600-541	SCREW (HI CART ONLY)	2
36	600-418	O-RING	2
	600-455	KIT, REPACKING (INCL.7,8,11,13,14,17,21-23)	1
	600-335	FLUID MANIFOLD COMPLETE (1-24, 26-32)	1
3	600-141-10	100 MESH FILTER	1

Both upper and lower packing are shown pushing off the shipping tool.  
 Tool is for shipping purposes only and not to be used for packing installation.

## **PAINT/FILTER MANIFOLD SERVICE AND REPAIR**

### **T7 UNITS ONLY**

#### **REPACKING PAINT/FILTER MANIFOLD**

**Follow pressure relief procedure before attempting to service or repair unit.**

1. Remove suction set by unthreading nut item # 85, see frame and siphon tube then pull downwards the inlet adaptor from intake housing # 20. Remove return hose #90 from pump/filter manifold. Remove suction set from unit.
2. Remove filter bowl #1 and filter and spring support #3 and 4. Inspect and clean or replace filter screen #3.
3. Remove intake valve housing #20.
4. Remove Piston guide #24 by inserting a ¼" slotted screwdriver in the gap between the upper side of the intake valve housing and the piston guide. Gently pry upwards until piston guide is free from intake valve housing.
5. Carefully inspect ball #17 and seat #18. If worn replace. Note seat #18 can be flipped over to the other side if worn or damaged. If repacking the unit is necessary always make sure to replace ball #17 and gaskets 22 and 21.
6. Insert ¼ Hex key into piston valve assembly # 16 and turn counter clockwise to remove piston valve # 15. Inspect upper ball #13 and carbide seat of piston valve #15. Replace if worn or damaged. Make sure to always replace upper ball #13 and o-ring #14 if repacking unit.
7. To remove the pump/filter manifold housing use a 5/16" Hex wrench in the 2 mounting bolts #25. Then unthread transducer #30 from the back of paint/filter manifold.
8. Remove crank housing cover plate # 55 diagram "B".
9. Insert a slotted screwdriver between crank housing # 53, see diagram "B" and fluid manifold # 9 gently pry downwards until a gap can be seen between # 9 and #53. Then slide pump/filter manifold # 9 from unit.
10. Using a 1" open end or adjustable wrench to remove upper retainer #6.
11. Remove piston rod # 12 by pushing downward with your hand.
12. Inspect upper and lower packings #8 and #11 in place. Do not remove packings to inspect. Remove only if you intend to replace them.
13. When replacing packings make sure to fill the inside of the packings with "packing grease" supplied in repair kit 600-455. Also apply grease on o-ring on the outside of the packing to make insertion easier.
14. Remove upper packing from shipping tool. Insert upper packing in to the top of pump/filter manifold #9. Packing can only go in one direction.
15. Remove lower packing from shipping tool. Insert lower packing #11 in the bottom of the pump/filter manifold. Packing can only go in one direction.
16. Thread upper retainer #6 after replacing upper guide #7. Leave hand tight until piston is installed.
17. Insert upper ball #13 into piston #12 while holding piston upside down.
18. Thread piston valve #15 into piston. Make sure to replace o-ring #14.
19. Using connecting rod item #56 (see diagram "B") to hold piston use a ¼" hex wrench to tighten piston valve firmly into piston.
20. Replace o-rings #23, 22 and 21 below seat in intake valve and on Piston Guide. Insert lower ball and seat #'s 17 and 18 and firmly push piston guide into intake valve housing #20.
21. Slide piston # 12 into intake valve housing assembly. Insert piston through lower packing until it stops. Then thread intake valve assembly into pump/filter manifold. The intake valve housing assembly will push piston through packings correctly. Once intake valve housing is threaded all the way use needle nose pliers on the slots of the top of the piston to align slots front to back.
22. Using a 1" open end wrench or adjustable wrench tighten upper retainer # 6 firmly.

23. If connecting rod is not in the down position plug unit in and cycle unit to get connecting rod into down position.
24. With piston slots aligned slide pump/filter manifold onto connecting rod #56 Diagram "B". Push pump/filter manifold towards crank housing # 53 to line up dowel pins then thread mounting bolts #25 through pump filter manifold and thread into crank housing #53. Tighten firmly with 5/16" Hex wrench.
25. Reattach transducer #30 to the back of pump/filer manifold.
26. Reinstall crankshaft cover plate #55 with 4 screws #40. See diagram "B".
27. Reattach suction set.
28. Pour Trilube through slot in cover plate #55, diagram "B".

#### REPLACE BY-PASS VALVE

1. To replace the pressure relief valve #27 knock pin #29 through black handle #28.
2. Remove black plastic handle and cap with indexing pin which exposes pressure relief valve.
3. Using a 3/4" open end unthread by pressure relief valve. Inspect. Replace if worn.

#### REPLACE FILTER

1. To replace the paint filter remove filter bowl #1 from fluid manifold by unthreading counter clockwise.
2. Remove filter #3 and spring support #4. Most times filter can just be cleaned but if damaged replace.

#### REPLACE TRANSDUCER

1. To replace transducer hold wire tube of #31 with plyers and unthread transducer housing #30 from pump/filter manifold.
2. Remove mounting screws # 25.
3. Remove 4 screws for crank housing cover plate # 55.
4. With a flat blade screwdriver pry pump/filter manifold downward till it clears locating pins and slide forward but do not remove.
5. Remove 4 screws #40 and Control box cover plate #70.
6. Unplug transducer from circuit board. See diagram "B".
7. Guide transducer wire out of control box.
8. To replace guide replacement transducer through grommet #91 and reconnect to circuit board.
9. Thread transducer into pump/filter housing.
10. Replacement of transducer requires no calibration of pressure control. To ensure new transducer functions properly follow Start up procedure.



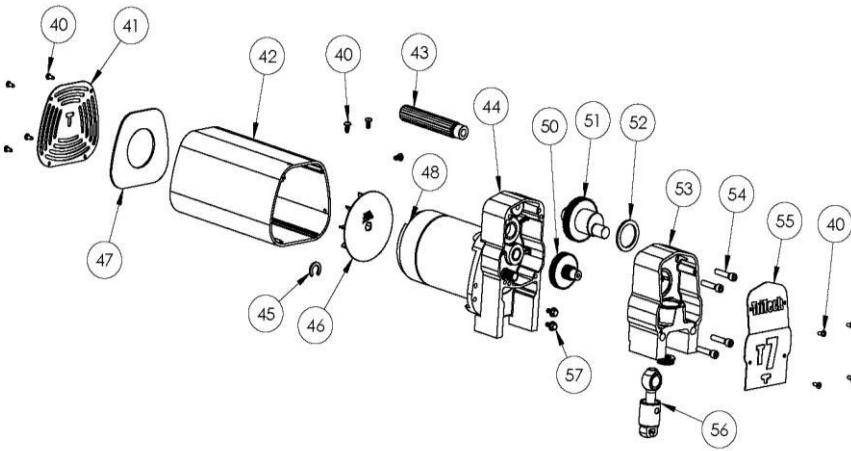

**(B) MOTOR & GEARBOX**

ITEM NO	PART NUMBER	DESCRIPTION	QTY
40	600-359	SCREW	11
41	600-0186	PLATE, REAR	1
42	600-580	COVER (INCL.40-41)	1
43	600-331	HANDLE	1
44	600-545	MOTOR 110V COMPLETE (INCL.45-48)	1
44	600-546	MOTOR 220V COMPLETE (INCL.45-48)	1
45	600-494	SNAP RING	1
46	600-356	FAN	1
47	600-558	BAFFLE	1
48	600-581	BRUSH 110V (2)	1
48	600-582	BRUSH 220V (2)	1
50	600-178	GEAR, REDUCER	1
51	600-185-75	CRANKSHAFT	1
52	600-307	WASHER, THRUST	1
53	600-317	HOUSING, CRANK	1
54	600-316	BOLT	4
55	600-113	COVER, FRONT	1
56	600-0108	CONNECTING ROD	1
57	600-401	SCREW (CONTROL BOX TO GEARBOX)	2

**(C) CONTROL BOX**

ITEM NO	PART NO.	DESCRIPTION	QTY
40	600-359	SCREW	4
70	600-485	PLATE (INCL. 71)	1
71	600-417	GASKET	1
72	600-503	SCREW	4
73	600-628	CIRCUIT BOARD 110V	1
73	600-629	CIRCUIT BOARD 220v	1
75	600-131	POWER CORD 110V	1
75	600-151	POWER CORD 220V	1
75	600-639	POWER CORD 220V AUSTRALIA	1
75	600-481	POWER CORD 110V UK	1
76	600-128	CORDGRIP, STRAIN RELIEF	1
77	600-129	LOCKNUT, STRAIN RELIEF	1
78	600-411	SCREW	2
79	600-122	COVER, SWITCH 110V	1
79	600-124	COVER, SWITCH 220V	1
80	600-121	SWITCH 110V	1
80	600-126	SWITCH 220V	1
81	600-366	WIRE, SWITCH TO BOARD	1
82	600-364	POTENTIOMETER (INCL.83,97)	1
83	600-419	O-RING	1
84	600-264-1	EDGE MOUNT TOP	1
	600-264-2	EDGE MOUNT BOTTOM	1
85	600-123	KNOB	1
86	600-271	GROMMET, MOTOR	1
87	600-218	BRACKET	1
88	101-001	O-RING	2
89	600-456	TRANSDUCER (INCL.88,90)	1
90	600-030	HOUSING, TRANSDUCER	1
91	600-337	GROMMET, TRANSDUCER	1
92	599-336	BOX, CONTROL SHELL 110V	1
92	599-337	BOX, CONTROL SHELL 220V	1
92	599-338	BOX, CONTROL SHELL 220V AUSTRALIA EMC COMPLIANT	
93	600-519	SCREW, GROUND WIRE	1
94	600-487	FILTER, X2 CAPPACITOR AUSTRALIA EMC COMPLIANT	1
95	600-285	ASSY. AC LINE FILTER AUSTRALIA EMC COMPLIANT	1
96	600-618	SCREW, FOR AC LINE FILTER	2
97	501-082	LOCKNUT, FOR AC LINE FILTER	2
	600-635	CONTROL BOX 110VCOMPLETE (INCL.40, 70-93)	1
	600-636	CONTROL BOX 220VCOMPLETE (INCL.40, 70-93)	1
	600-637	CONTROL BOX 220VCOMPLETE (INCL.40, 70-96) AUSTRALIA EMC COMPLIANT	
	600-638	CONTROL BOX 110V UK COMPL. (INCL.40,70-93)	1

**(C) CONTROL BOX**

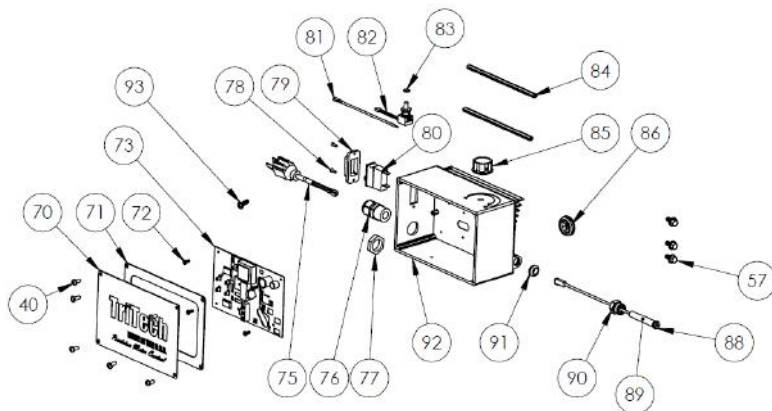
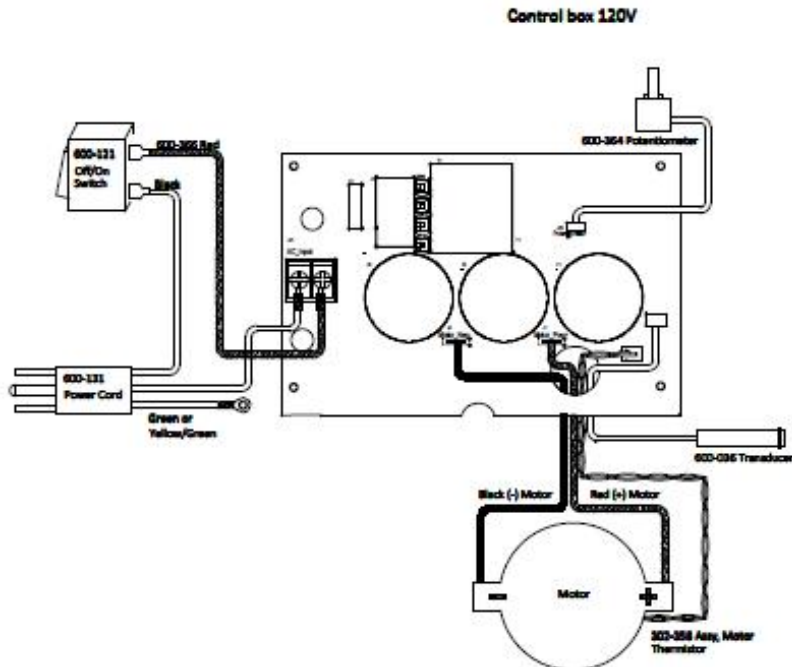
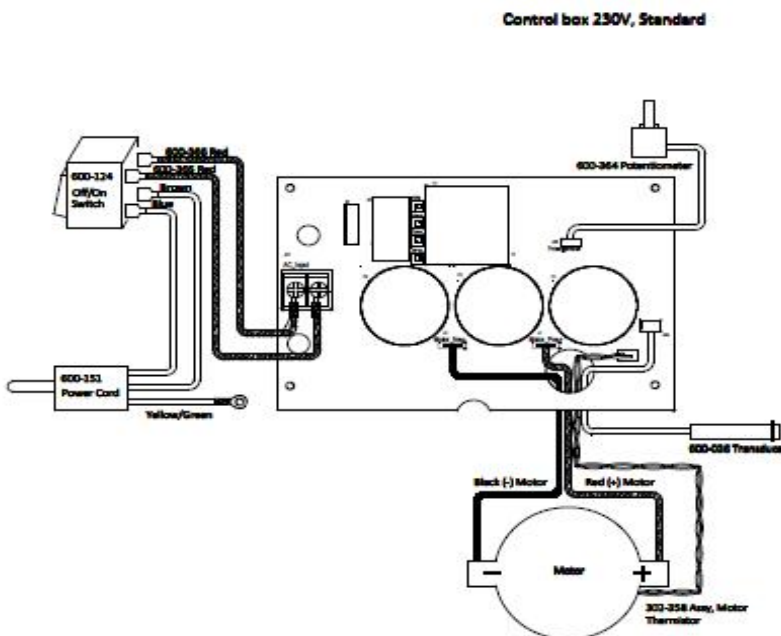

Diagram E

REV B 110V



REV B 220V



#### REPLACE CONTROL BOX

**Follow pressure relief procedure before attempting to service or repair unit.**

1. If trouble shooting guide suggests replacing the control box follow the directions below.
2. Remove 4 screws #40 and remove cover plate #70.
3. Unthread transducer from fluid manifold #9.
4. Disconnect motor and cap leads from circuit board. See Diagram "D/E"
5. Remove 2 mounting screws #57 from bracket #87. Unthread filter housing for easier access.
6. Remove control box containing circuit board, On/Off switch and potentiometer
7. Replace in reverse order. Note: By removing motor housing will make it easier to install control box.

Note: Although the Circuit board, transducer, On/Off switch and potentiometer are sold individually they are supplied together with replacement Control Box assembly.

#### REPLACE CIRCUIT BOARD

**Follow pressure relief procedure before attempting to service or repair unit.**

If trouble shooting guide suggests replacing the Circuit Board follow the directions below.

1. Remove 4 screws #40 and remove cover plate #70.
2. Disconnect Transducer #89 from circuit board. See diagram "D/E" and for below.
3. Disconnect the leads from potentiometer #82 to circuit board
4. Disconnect the leads from motor # 44 to the circuit board
5. Disconnect lead from On/Off switch #80 to circuit board.
6. Remove 4 screws #74 mounting Circuit Board.
7. Replace in reverse order.

Note: It is recommended to wear surgical gloves when handling circuit board. They will reduce contaminants that may come in contact with the circuit board.

#### REPLACE POTENTIOMETER

**Follow pressure relief procedure before attempting to service or repair unit.**

If trouble shooting guide suggests replacing the potentiometer follow the directions below.

1. Remove 4 screws #40 and remove cover plate #70.
2. Disconnect the leads from potentiometer # 82 to circuit board and remove knob #85. Remove potentiometer # 82.
3. Replace in reverse order.

#### REPLACE TRANSDUCER

**Follow pressure relief procedure before attempting to service or repair unit.**

If trouble shooting guide suggests replacing the transducer follow the directions below.

4. Remove 4 screws #40 and remove cover plate #70.
5. Unplug the wire from #89 to circuit board.
6. Loosen housing #90 and with needle nose pliers slide transducer from filter manifold.
7. Remove 2 screws #57. Make sure to firmly hold control box in place.
8. Remove transducer by guiding the wire through the circuit board and out the back of the control box.

9. Install new transducer by sliding the wire through grommet #91 and guiding the wire through grommet #86 and continuing through the circuit board.
10. Connect transducer to the circuit board and reinstall screws #57.
11. With needle nose pliers slide transducer into filter manifold making sure o-ring #88 stays in place.
12. Tighten housing #90 and install cover plate #70 with 4 screws #40.

#### REPLACE ON/OFF SWITCH

##### **Follow pressure relief procedure before attempting to service or repair unit.**

If trouble shooting guide suggests replacing the on/off switch follow the directions below.

1. Remove 4 screws #40 and remove cover plate #70.
2. Disconnect the two leads from the on/off switch.
3. Remove mounting screws #78.
4. Remove switch indicator plate #79 and remove the on/off switch #80.
5. Replace in reverse order.

#### REPLACE MOTOR BRUSHES:

##### **Follow pressure relief procedure before attempting to service or repair unit.**

If trouble shooting guide suggests replacing the motor brushes follow the directions below.

1. Remove 3 screws #40 and remove cover #42.
2. Use a straight blade screwdriver to remove brush retaining cap to expose motor brushes.
3. Remove motor brushes #48 one at a time. Inspect. Replace if worn or damaged
4. Reassemble in reverse order. When reinstalling motor brushes make sure to have red and black wire leads to the back of the motor housing.

#### REPLACE MOTOR

##### **Follow pressure relief procedure before attempting to service or repair unit.**

If trouble shooting guide suggests replacing the motor follow the directions below.

1. Remove 3 screws #40 and remove motor cover #42.
2. Remove 4 screws #40 and remove cover plate #70.
3. Disconnect Black and Red cap/motor leads from circuit board #73. See diagram "D/E"
4. Remove 4 screws #40 and remove cover plate # 55.
5. Unthread Transducer housing # 90 and slide Transducer #89 back from Fluid Manifold.
6. Remove 4 screws #54 and remove crank housing and fluid manifold together.
7. Remove crankshaft #51 and thrust washer #52.
8. Remove reducer gear #50
9. Remove 2 screws # 57 from underneath. Leave 2 screws #57 that attach bracket #87 to control box #92.
10. Remove 4 screws #96 see diagram frame and siphon tubes and separate motor complete from frame.
11. Install reducer gear # 50 into gear box and rotate fan to insure armature shaft is engaged.
12. Install crankshaft and thrust washer #51, 52.
13. Fill gear box with # 2 lithium base grease.
14. Reconnect black and red cap/motor and transducer leads to circuit board in control box.
15. Complete reassemble in reverse order.

## REPLACE GEARS/CONNECTING ROD

**Follow pressure relief procedure before attempting to service or repair unit.**

If trouble shooting guide suggests replacing the gears or connecting rod follow the directions below.

1. Remove 4 screws #40 and remove cover plate #55.
2. Remove 4 screws #40 and remove cover plate #70.
3. Remove 2 screws #25 and unthread transducer # 30 (see diagram "A") and remove pump/filter manifold.
4. Remove 4 screws # 54 then remove crank housing. Connecting rod can be replaced at this point.
5. The reducer gear #50 and crankshaft #51 can also be replaced at this point.
6. Complete reassemble in reverse order.

## FRAMES and SYPHON TUBES

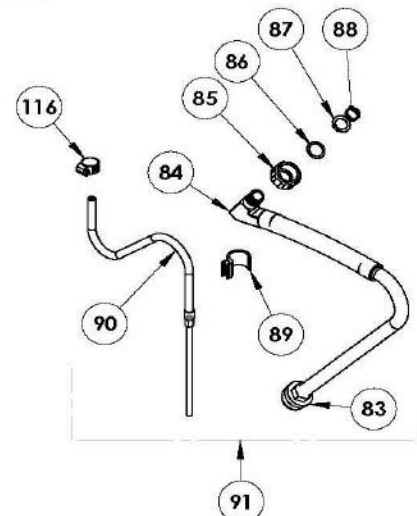
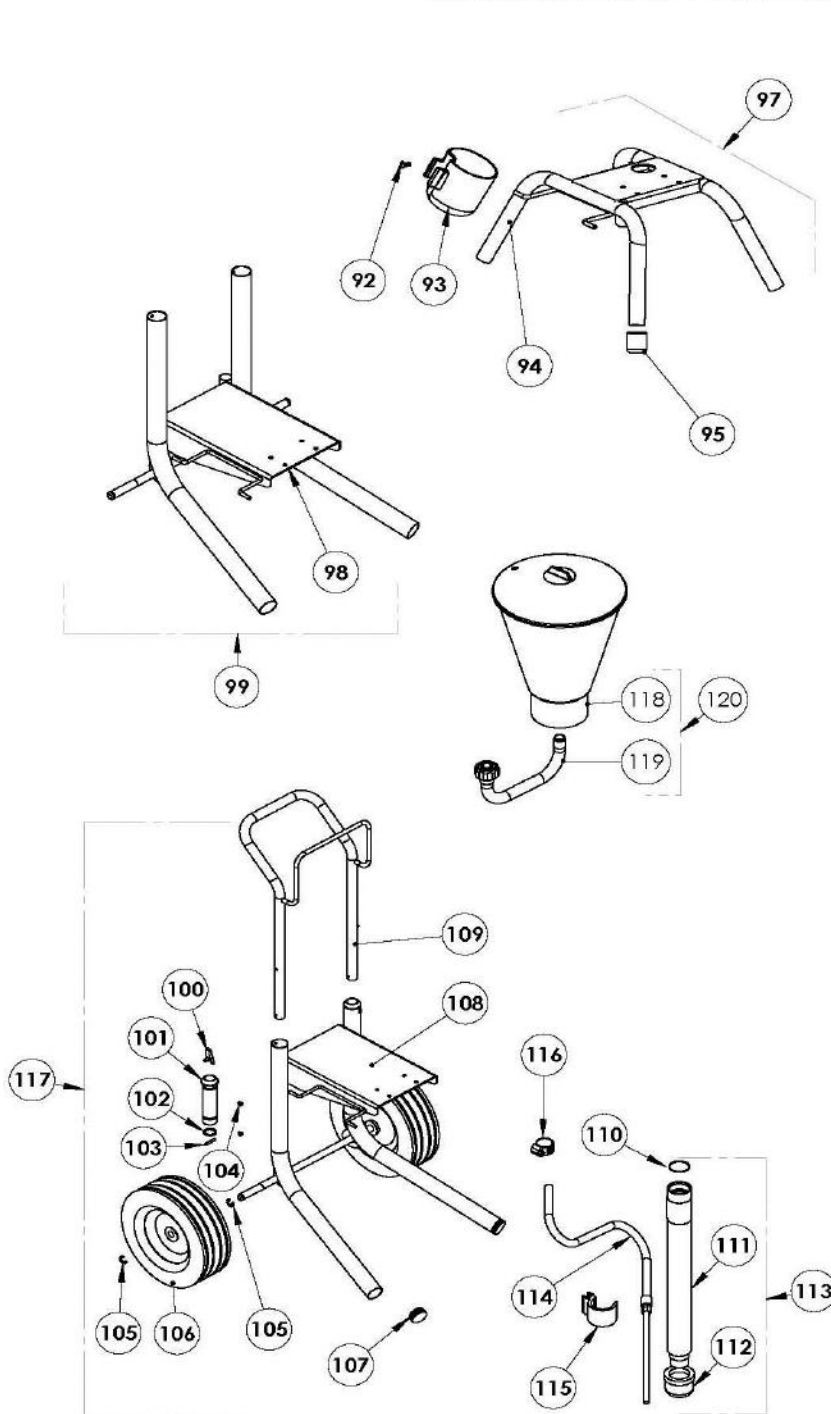

ITEM N/O	PART NO.	DESCRIPTION	QTY
83	600-066	SCREEN	1
84	600-213	SYPHON HOSE ASSY	1
85	600-233	NUT	1
86	600-168	GASKET	1
87	600-236	SNAP RING	1
88	600-164	O-RING	2
89	600-442	CLIP, HOSE	1
90	600-212	PRESSURE RELIEF HOSE	1
91	600-221	SYPHON & PRESS. RELIEF HOSES	1
92	600-198	SCREW	1
93	600-385	CUP	1
94	600-215	STAND CART	4
95	600-398	FRAME CAP (STAND)	4
96	600-401	SCREW	4
97	600-407	STAND CART COMPLETE (INCL. 92-95)	1
98	600-429	LO CART BOTTOM FRAME	1
99	600-430	LO CART COMPLETE	1
100	600-391	SPRING PIN	2
101	600-378	HANDLE GUIDE	2
102	600-379	WASHER	2
103	600-381	PIN	2
104	600-382	SCREW	4
105	600-399	SNAP RING	4
106	600-373	WHEEL	2
107	600-397	FRAME CAP (CART)	2
108	600-389	HI CART BOTTOM FRAME	1
109	600-371	HANDLE	1
110	600-406	O-RING (HIGH CART ONLY)	1
111	600-396	DOWN TUBE (HC ONLY)	1
112	600-085-15	SCREEN 15 MESH (HC ONLY)	1
113	600-404	KIT, DOWN TUBE (INCL. 111-113)	1
114	600-512	PRESSURE RELIEF HOSE (HI CART)	1
115	600-471	CLIP (HI CART)	1
116	600-542	CLAMP, PRESSURE RELIEF HOSE	1
117	600-375	HI CART FRAME COMPLETE	1
118	600-553	HOPPER	1
119	600-539	TUBE, HOPPER	1
120	600-556	HOPPER KIT (INCL. 118-119)	1

# Warranty

TriTech Industries Inc. warrants all equipment referenced in this manual which is manufactured by TriTech to be free from defects in material and workmanship on the date of sale to the original purchaser for use. With the exception of any special, extended, or limited warranty published by TriTech, TriTech will, for a period of twelve months from the date of Sale, repair or replace any part of the equipment determined by TriTech to be defective. This warranty applies only when the equipment is installed, operated and maintained in accordance with TriTech's written recommendations.

This warranty does not cover, and TriTech shall not be liable for general wear and tear, or any malfunction, damage or wear caused by faulty installation, misapplication, abrasion, corrosion, inadequate or improper maintenance, negligence, accident, tampering, or substitution of non-TriTech component parts. Nor shall TriTech be liable for malfunction, damage or wear caused by the incompatibility of TriTech equipment with structures, accessories, equipment or materials not supplied by TriTech, or the improper design, manufacture, installation, operation or maintenance of structures, accessories, equipment or materials not supplied by TriTech.

This warranty is conditioned upon the prepaid return of the equipment claimed to be defective to TriTech or an authorized TriTech distributor/service center for verification of the claimed defect. If the claimed defect is verified, TriTech will repair or replace free of charge any defective parts. The equipment will be returned to the original purchaser transportation prepaid. If inspection of the equipment does not disclose any defect in material or workmanship, repairs will be made at a reasonable charge, which charges may include the costs of parts, labor, and transportation.

THIS WARRANTY IS EXCLUSIVE, AND IS IN LIEU OF ANY OTHER WARRANTIES, EXPRESS OR IMPLIED, INCLUDING BUT NOT LIMITED TO WARRANTY OF MERCHANTABILITY OR WARRANTY OF FITNESS FOR A PARTICULAR PURPOSE.

TriTech's sole obligation and buyer's sole remedy for any breach of warranty shall be as set forth above. The buyer agrees that no other remedy (including, but not limited to, incidental or consequential damages for lost profits, lost sales, injury to person or property, or any other incidental or consequential loss) shall be available. Any action for breach of warranty must be brought within two (2) years of the date of sale.

TriTech MAKES NO WARRANTY, AND DISCLAIMS ALL IMPLIED WARRANTIES OF MERCHANTABILITY AND FITNESS FOR A PARTICULAR PURPOSE, IN CONNECTION WITH ACCESSORIES, EQUIPMENT, MATERIALS OR COMPONENTS SOLD BUT NOT MANUFACTURED BY TriTech. These items sold, but not manufactured by TriTech (such as electric motors, switches, hose, etc.), are subject to the warranty, if any, of their manufacturer. TriTech will provide purchaser with reasonable assistance in making any claim for breach of these warranties.

In no event will TriTech be liable for indirect, incidental, special or consequential damages resulting from TriTech supplying equipment hereunder, or the furnishing, performance, or use of any products or other goods sold hereto, whether due to a breach of contract, breach of warranty, the negligence of TriTech, or otherwise.

## ADDITIONAL WARRANTY COVERAGE

TriTech may provide extended warranty and wear warranty for products described in the "TriTech Extended Warranty Program".

TriTech Industries Inc. 610 Rahway Avenue, Union N.J. 07083 908-378-1080 fax 908-378-1659 [www.tritechindustries.com](http://www.tritechindustries.com)